

## HIGH CAPACITY FLOAT AND ORIFICE STEAM TRAPS FLT 120 S (Fabricated steel) DN150

### DESCRIPTION

FLT120S float and orifice steam traps series are designed for all types of low pressure steam heating and process equipment.

Typical applications include unit heaters, heat exchangers, driers, jacketed vessels and all the applications where continuous drainage is essential.

Specially designed for the sugar industry where extremely high flow rates are involved.

Connections are flanged.

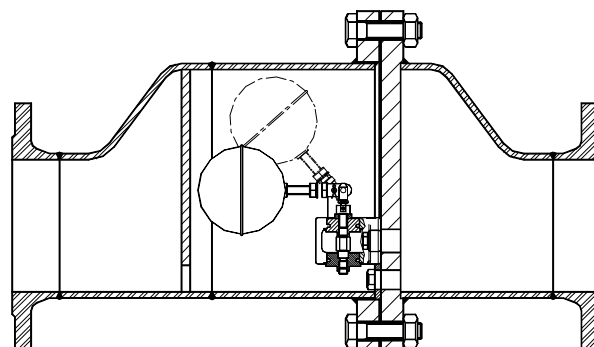

### MAIN FEATURES

Modulating discharge.

Discharges condensate at steam temperature.

Unaffected by sudden or wide load and pressure changes.

Excellent air discharge (by high capacity thermostatic air vent)

- OPTIONS: Special designs  
 USE: Saturated steam.  
 AVAILABLE MODELS: FLT120S  
 SIZES: DN 150  
 CONNECTIONS: Flanged EN 1092-1 PN16 or ANSI  
 INSTALLATION: Horizontal standard installation.

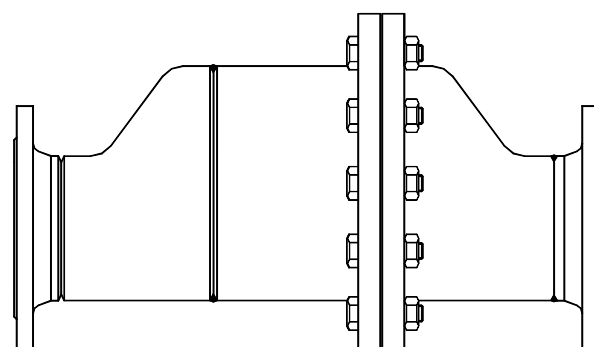

BODY LIMITING CONDITIONS	
FLANGED PN 16 / ANSI 150 *	RELATED TEMP.
ALLOW. PRES.	
14,8 bar	100 °C
13,3 bar	200 °C
12,1 bar	250 °C
11 bar	300 °C

PMO - Max. operating pressure 4 bar

TMO - Max. operating temperature 250 °C

\* According to EN1092-1:2007

FLOW RATE CAPACITY WITH ONE MECHANISM AND ORIFICE IN Kgs/h							
Dif. Press. bar	DN 150						ΔQmax
	01	02	03	04	05	06	
0,1	12500	14300	16800	23900	38800	46600	9000
0,3	14700	17600	21500	32700	48500	68700	10000
0,7	18000	22000	27600	43500	65700	94400	12000
1	19500	24300	31300	50600	77900	112900	12500
1,4	21300	26900	34800	57200	88700	129200	13500
2	24000	30900	40500	68100	128200	156200	15000
<b>Orifice Nr.</b>	<b>01</b>	<b>02</b>	<b>03</b>	<b>04</b>	<b>05</b>	<b>06</b>	

CE MARKING (PED - European Directive 97/23/EC)	
Rated PN 10	Category
FLT120S - DN150	2 (CE Marked)
Rated PN 16	Category
FLT120S - DN150	2 (CE Marked)

Example: One FLT120 DN150-04 (with orifice nr.4), operating at a D.P. of 0,7 bar, must have a minimum flow of 31500Kgs/h (43500-12000). The minimum flow rate is necessary to ensure that the orifice does not waste steam.

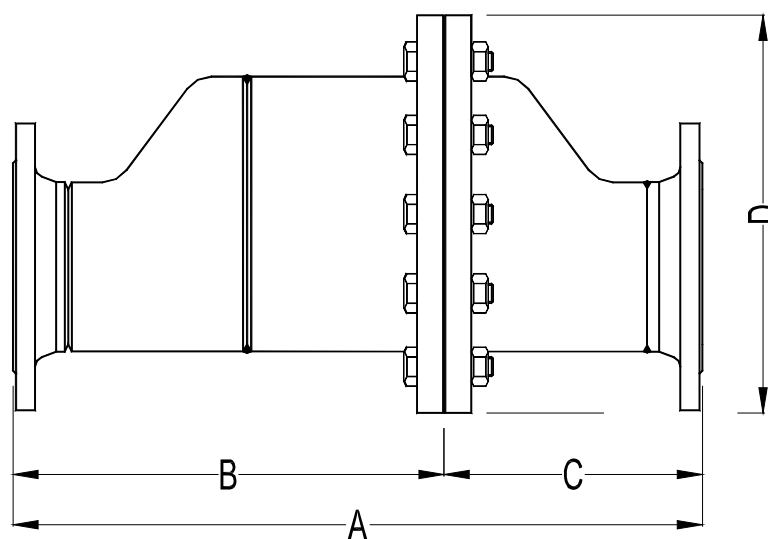

DIMENSIONS (mm)						
MODEL	SIZE DN	A	B	C	D	WGT. Kgs
FLT 120S	150	685	430	255	395	96

MATERIALS		
POS.N r.	DESIGNATION	MATERIAL
1	Body	P250GH / 1.0460 ; P235GH / 1.0305 ; S355J2G3 / 1.0570 ; S235JRG2/1.0038
2	Cover	P250GH / 1.0460 ; P235GH / 1.0305 ; S355J2G3 / 1.0570 ; S235JRG2/1.0038
3	*Gasket	Graphite
4	*Seat	CF8 / 1.4308
5	*Valve	AISI420 / 1.4021; CF8M / 1.4408
6	*Lever	AISI316 / 1.4401 ; AISI304 / 1.4301
7	*Float	AISI304 / 1.4301
8	Bolts	Steel 8.8

\*Available spare parts.

